

The background of the entire page is a detailed, high-contrast photograph of various welding tools. In the foreground, a green and black welding torch is prominent, angled towards the bottom right. Behind it, there are several wire brushes with metal bristles, and other tools like pliers and wrenches are scattered in the background. The lighting is dramatic, highlighting the metallic textures and the green accents of the torch.

TRANSLAS
DUTCH WELDING TECHNOLOGY



On-Gun Welding Fume Extraction

CONTROL WELDING FUME AT THE SOURCE

On-gun fume extraction is too heavy, too bulky, and impacts the shielding gas...
Not anymore.

On-gun fume extraction is one of the safest and most effective methods of controlling welding fume and is heavily used and relied upon in Europe and North America. However, for the reasons above, on-gun extraction has not been adopted in Australia or New Zealand.

AWS has teamed up with Translas, Dutch on-gun fume extraction specialist, to launch an industry first: a range of lightweight, manoeuvrable, and ergonomic extraction guns that deliver the highest capture rate on the market (up to 98%), while leaving the shielding gas completely unaffected.

No other welding fume control solution captures welding fume at the source, removes it from the environment, and most importantly, follows the welder as they move. Experience Translas fume extraction technology today.

UP TO **98% CAPTURE RATE**
AND **100% DUTY CYCLE**

**REMOVES FUME AND
FOLLOWS THE WELDER**

UNLIKE OTHER FORMS OF LEV





Welding Fume Is Serious. Action Is Required.

The important point to understand is that while the risk posed by welding fume is serious, keeping yourself safe can be straightforward.

The 2017 IARC reclassification of welding fume as ‘carcinogenic to humans’ simply confirmed what was already known – welding fume is extremely bad for health and workplaces must protect their workers. Excessive exposure to welding fume can cause multiple types of cancer, including lung, larynx, and urinary tract.

‘Welders present, on average, a 43% increased risk of lung cancer when compared with those who have never welded or been exposed to welding fume’¹. ‘This increased risk of lung cancer is regardless of the type of steel welded, the welding process and independent of exposure to smoking’¹. Precedent for workers’ compensation based on a link between welding fume and cancer was established in the Australian courts back in 2014, opening the door for future compensation claims.

Aside from cancer, welding fume can also cause serious long-term health effects like lung function

Simple Takeaway

**Welding fume is serious,
action is required.**

abnormalities, including bronchial asthma, chronic obstructive pulmonary disease (COPD), pneumoconiosis and other pulmonary fibrosis, as well as stomach ulcers, kidney damage and nervous system damage.

Recognising welding fume as carcinogenic and the other associated health risks should encourage all employers of welders to review their risk assessments and revise their control measures.

Welding fume is serious, action is required.



TRANSLAS

DUTCH WELDING TECHNOLOGY



The safest and most effective method.



Extraction at the source is the safest and most effective solution to control welding fume in the work environment. Translas on-gun fume extraction captures harmful welding fumes and individual particulates as soon as they are generated, keeping the welder protected and the work environment fume free.

Up to 98% capture rate and 100% duty cycle.



Translas leads the industry with a fume capture rate up to 98%. However, like the eye of a storm, the cyclonic extraction effect leaves the shielding gas completely unaffected. The Translas range of fume guns are built tough and offer a 100% duty cycle.



Super lightweight & ergonomic fume gun.



On-gun fume extraction can no longer be considered too heavy and cumbersome, as Translas fume guns are the same weight or lighter than most standard welding guns. Moreover, the small ergonomic handle makes it one of the most comfortable guns to work with for any welder.

Low maintenance with self-cleaning.



The extraction system has an automatic cleaning function. The moment the pressure in the filter is too high, the units begin to automatically clean the filters. A variable frequency drive motor ensures extraction flow rates are always maintained at a precise level, making this powerful solution suitable for high production welding environments.

A potential option for confined spaces.



On-gun fume extraction captures welding fume before it can be released into the environment or build up around the welder, making Translas a potential option for confined spaces*. Due to the powerful variable frequency motor, the extraction unit can be positioned over 20 metres away from the welder and still deliver the same industry leading capture rate of up to 98%.

* Confined spaces can be deadly and decisions on how to handle a specific confined space must be assessed on the spot and always comes down to the specifics of the individual situation. There should be a suitably trained and knowledgeable person doing the assessment and design of a safe system for any confined space entry.

1. SELECT YOUR ON-GUN EXTRACTION PACKAGE



TRANSLAS 8XE 250 MINI MIG EXTRACTION SYSTEMS

Translas 250 On-Gun Fume Extraction System
ONE PERSON/ONE GUN

Part Number
TR250S

TRANSLAS 
DUTCH WELDING TECHNOLOGY

NEW

SELECT FOR WELDING BELOW 250 AMPS



AIR COOLED



[Learn more](#)

- ✓ 250 amp air cooled on-gun fume extraction system
- ✓ Up to 98% capture rate leaves shielding gas unaffected
- ✓ Ergonomic and super lightweight welding gun
- ✓ Extraction system self cleans with auto start and stop
- ✓ 100% duty cycle with Euro connection
- ✓ Kit includes everything you need to get started with on-gun extraction

Translas 250 On-Gun Fume Extraction System
TWO PERSON/TWO GUN

Part Number
TR250D

TRANSLAS 
DUTCH WELDING TECHNOLOGY

NEW

SELECT FOR WELDING BELOW 250 AMPS



AIR COOLED



[Learn more](#)

- ✓ Two person 250 amp air cooled on-gun fume extraction system
- ✓ Up to 98% capture rate leaves shielding gas unaffected
- ✓ Two ergonomic and super lightweight welding guns
- ✓ Extraction system self cleans with auto start and stop
- ✓ 100% duty cycle with Euro connection
- ✓ Kit includes everything you need to get started with on-gun extraction



TRANSLAS 8XE 400 MIG EXTRACTION SYSTEMS

Translas 400 On-Gun Fume Extraction System
ONE PERSON/ONE GUN

Part Number
TR400S



NEW

SELECT FOR WELDING 250 - 400 AMPS



AIR COOLED



[Learn more](#)

- ✓ 400 amp air cooled on-gun fume extraction system
- ✓ Up to 98% capture rate leaves shielding gas unaffected
- ✓ Ergonomic and super lightweight welding gun
- ✓ Extraction system self cleans with auto start and stop
- ✓ 100% duty cycle with Euro connection
- ✓ Kit includes everything you need to get started with on-gun extraction

Translas 400 On-Gun Fume Extraction System
TWO PERSON/TWO GUN

Part Number
TR400D



NEW

SELECT FOR WELDING 250 - 400 AMPS

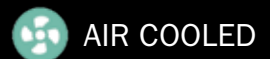

AIR COOLED



[Learn more](#)

- ✓ Two person 400 amp air cooled on-gun fume extraction system
- ✓ Up to 98% capture rate leaves shielding gas unaffected
- ✓ Two ergonomic and super lightweight welding guns
- ✓ Extraction system self cleans with auto start and stop
- ✓ 100% duty cycle with Euro connection
- ✓ Kit includes everything you need to get started with on-gun extraction

1. SELECT YOUR ON-GUN EXTRACTION PACKAGE



TRANSLAS 8XE 500 MIG EXTRACTION SYSTEMS

Translas 500 On-Gun Fume Extraction System
ONE PERSON/ONE GUN

Part Number
TR500S

TRANSLAS 
DUTCH WELDING TECHNOLOGY

NEW

SELECT FOR WELDING OVER 400 AMPS



WATER COOLED



[Learn more](#)

- ✓ 500 amp water cooled on-gun fume extraction system
- ✓ Up to 98% capture rate leaves shielding gas unaffected
- ✓ Ergonomic and super lightweight welding gun
- ✓ Extraction system self cleans with auto start and stop
- ✓ 100% duty cycle with Euro connection
- ✓ Kit includes everything you need to get started with on-gun extraction

Translas 500 On-Gun Fume Extraction System
TWO PERSON/TWO GUN

Part Number
TR500D

TRANSLAS 
DUTCH WELDING TECHNOLOGY

NEW

SELECT FOR WELDING OVER 400 AMPS



WATER COOLED



[Learn more](#)

- ✓ Two person 500 amp water cooled on-gun fume extraction system
- ✓ Up to 98% capture rate leaves shielding gas unaffected
- ✓ Two ergonomic and super lightweight welding guns
- ✓ Extraction system self cleans with auto start and stop
- ✓ 100% duty cycle with Euro connection
- ✓ Kit includes everything you need to get started with on-gun extraction

2. SELECT YOUR CONSUMABLES

250 AMP GUN CONSUMABLE OPTIONS			
Item	Part Number	Description	Pack Qty
A	TR3937000	Nozzle conical 12mm	5
	TR3937001	Nozzle conical 14mm tapered	5
B	TR3990091	Contact tip - CuCrZr tri metal nickel plated - for 0.9 wire	25
	TR3990101	Contact tip - CuCrZr tri metal nickel plated - for 1.0 wire	25
	TR3990121	Contact tip - CuCrZr tri metal nickel plated - for 1.2 wire	25
C	TR39327110	Tip adapter 250	10
D	TR301545	Plastic coated liner blue 4 metre - for 0.8 to 1.0 wire	1
	TR301555	Plastic coated liner blue 5 metre - for 0.8 to 1.0 wire	1
	TR302545	Plastic coated liner red 4 metre - for 0.8 to 1.2 wire	1
	TR302555	Plastic coated liner red 5 metre - for 0.8 to 1.2 wire	1
	TR303645	Plastic coated liner yellow 4 metre - for 1.2 to 1.6 wire	1
	TR303655	Plastic coated liner yellow 5 metre - for 1.2 to 1.6 wire	1

400 AMP GUN CONSUMABLE OPTIONS			
Item	Part Number	Description	Pack Qty
A	TR3937041	Nozzle conical 14mm tapered	5
	TR3937045	Nozzle conical 17mm tapered	5
B	TR3990091	Contact tip - CuCrZr tri metal nickel plated - for 0.9 wire	25
	TR3990101	Contact tip - CuCrZr tri metal nickel plated - for 1.0 wire	25
	TR3990121	Contact tip - CuCrZr tri metal nickel plated - for 1.2 wire	25
	TR3990161	Contact tip - CuCrZr tri metal nickel plated - for 1.6 wire	25
C	TR39327310	Tip adapter 400	10
D	TR303794	Plastic coated liner black 4 metre - for 0.9 to 1.2 wire	1
	TR303795	Plastic coated liner black 5 metre - for 0.9 to 1.2 wire	1
	TR303764	Plastic coated liner grey 4 metre - for 1.6 wire	1
	TR303765	Plastic coated liner grey 5 metre - for 1.6 wire	1

500 AMP GUN CONSUMABLE OPTIONS			
Item	Part Number	Description	Pack Qty
A	TR3937041	Nozzle conical 14mm tapered	5
	TR3937045	Nozzle conical 17mm tapered	5
B	TR3990091	Contact tip - CuCrZr tri metal nickel plated - for 0.9 wire	25
	TR3990101	Contact tip - CuCrZr tri metal nickel plated - for 1.0 wire	25
	TR3990121	Contact tip - CuCrZr tri metal nickel plated - for 1.2 wire	25
	TR3990161	Contact tip - CuCrZr tri metal nickel plated - for 1.6 wire	25
C	TR39327210	Tip adapter 500	10
D	TR302545	Plastic coated liner red 4 metre - for 0.8 to 1.2 wire	1
	TR302555	Plastic coated liner red 5 metre - for 0.8 to 1.2 wire	1
	TR303645	Plastic coated liner yellow 4 metre - for 1.2 to 1.6 wire	1
	TR303655	Plastic coated liner yellow 5 metre - for 1.2 to 1.6 wire	1

250 AMP GUN A, B, C, & D are all required

- A. Select nozzle size
- B. Select contact tip based on wire size
- C. Tip adapter required
- D. Select a liner based on wire size

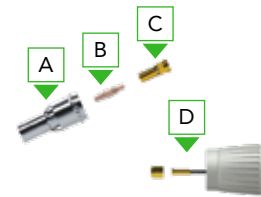

400 AMP GUN A, B, C, & D are all required

- A. Select nozzle size
- B. Select contact tip based on wire size
- C. Tip adapter required
- D. Select a liner based on wire size

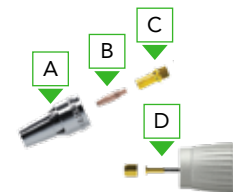

500 AMP GUN A, B, C, & D are all required

- A. Select nozzle size
- B. Select contact tip based on wire size
- C. Tip adapter required
- D. Select a liner based on wire size

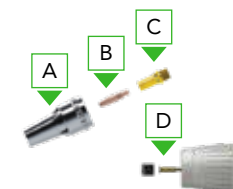

TECHNICAL SPECIFICATIONS



Specification	Translas 8XE 250 Amp On-Gun Fume Extraction System	Translas 8XE 250 Amp On-Gun Fume Extraction Double System	Translas 8XE 400 Amp On-Gun Fume Extraction System
Part Number	TR250S	TR250D	TR400S
Number of Users	1	2	1
Recommended Amps	250 Amps and below	250 Amps and below	250 - 400 Amps
Air/Water Cooled	Air Cooled	Air Cooled	Air Cooled
CO ²	280 Amp	280 Amp	420 Amp
Mixed Gases	250 Amp	250 Amp	400 Amp
Duty Cycle	100%	100%	100%
Fume Capture Rate	Up to 98%	Up to 98%	Up to 98%
Gun Rotation	360° Swivel	360° Swivel	360° Swivel
Automatic Start/Stop	Yes	Yes	Yes
Auto Filter Cleaning	Yes	Yes	Yes
Dimensions	(L x B x H) 700 x 440 x 585 / 630mm (without / with wheels)	(L x W x H) 700 x 530 x 560 / 630mm (without / with wheels)	(L x B x H) 700 x 440 x 585 / 630mm (without / with wheels)
Implementation	Mobile on 4 wheels - 2 rotating with locks	Mobile on 4 wheels - 2 rotating with locks	Mobile on 4 wheels - 2 rotating with locks
Power Supply	380-480V (3 Phase)	380-480V (3 Phase)	380-480V (3 Phase)
Motor Power	1.5 KW	Maximum 3.0 KW	1.5 KW
Suction Flow (Torch)	Target: 33 CFM / Max: 38 CFM	Target: 33 CFM / Max: 38 CFM	Target: 33 CFM / Max: 38 CFM
Filter Surface	5m ² Active filter surface, filter efficiency: IFA >99.8%	5m ² Active filter surface, filter efficiency: IFA >99.8%	5m ² Active filter surface, filter efficiency: IFA >99.8%
Working Temperature	0 to +50°C	0 to +50°C	0 to +50°C
Weight	45kg	58kg	45kg
Noise Level	Max. dB(A) <65dB(A) (at 100% suction flow)	Max. dB(A) <65dB(A) (at 100% suction flow)	Max. dB(A) <65dB(A) (at 100% suction flow)
Certifications	CE (European), W3 (Germany), and CSA (North America)	CE (European), W3 (Germany), and CSA (North America)	CE (European), W3 (Germany), and CSA (North America)
Compressed Air (Cleaning)	80 PSI (5.5 Bar), Dry/Clean Air, 20 CFM, Standard Size Airline	80 PSI (5.5 Bar), Dry/Clean Air, 20 CFM, Standard Size Airline	80 PSI (5.5 Bar), Dry/Clean Air, 20 CFM, Standard Size Airline

Kits include everything you need to get started with on-gun fume extraction: fume gun(s), extraction unit, hose(s), sensing cable(s), compressed air valve, airflow metre, filters, consumables (tip, tip adapter, nozzle, liner).



Translas 8XE 400 Amp On-Gun Fume Extraction Double System	Translas 8XE 500 Amp On-Gun Fume Extraction System	Translas 8XE 500 Amp On-Gun Fume Extraction Double System
TR400D	TR500S	TR500D
2	1	2
250 - 400 Amps	Over 400 Amps	Over 400 Amps
Air Cooled	Water Cooled	Water Cooled
420 Amp	550 Amp	550 Amp
400 Amp	500 Amp	500 Amp
100%	100%	100%
Up to 98%	Up to 98%	Up to 98%
360° Swivel	360° Swivel	360° Swivel
Yes	Yes	Yes
Yes	Yes	Yes
(L x W x H) 700 x 530 x 560 / 630mm (without / with wheels)	(L x B x H) 700 x 440 x 585 / 630mm (without / with wheels)	(L x W x H) 700 x 530 x 560 / 630mm (without / with wheels)
Mobile on 4 wheels - 2 rotating with locks	Mobile on 4 wheels - 2 rotating with locks	Mobile on 4 wheels - 2 rotating with locks
380-480V (3 Phase)	380-480V (3 Phase)	380-480V (3 Phase)
Maximum 3.0 KW	1.5 KW	Maximum 3.0 KW
Target: 33 CFM / Max: 38 CFM	Target: 33 CFM / Max: 38 CFM	Target: 33 CFM / Max: 38 CFM
5m ² Active filter surface, filter efficiency: IFA >99.8%	5m ² Active filter surface, filter efficiency: IFA >99.8%	5m ² Active filter surface, filter efficiency: IFA >99.8%
0 to +50°C	0 to +50°C	0 to +50°C
58kg	45kg	58kg
Max. dB(A) <65dB(A) (at 100% suction flow)	Max. dB(A) <65dB(A) (at 100% suction flow)	Max. dB(A) <65dB(A) (at 100% suction flow)
CE (European), W3 (Germany), and CSA (North America)	CE (European), W3 (Germany), and CSA (North America)	CE (European), W3 (Germany), and CSA (North America)
80 PSI (5.5 Bar), Dry/Clean Air, 20 CFM, Standard Size Airline	80 PSI (5.5 Bar), Dry/Clean Air, 20 CFM, Standard Size Airline	80 PSI (5.5 Bar), Dry/Clean Air, 20 CFM, Standard Size Airline

ON-GUN FUME EXTRACTION



AIR COOLED

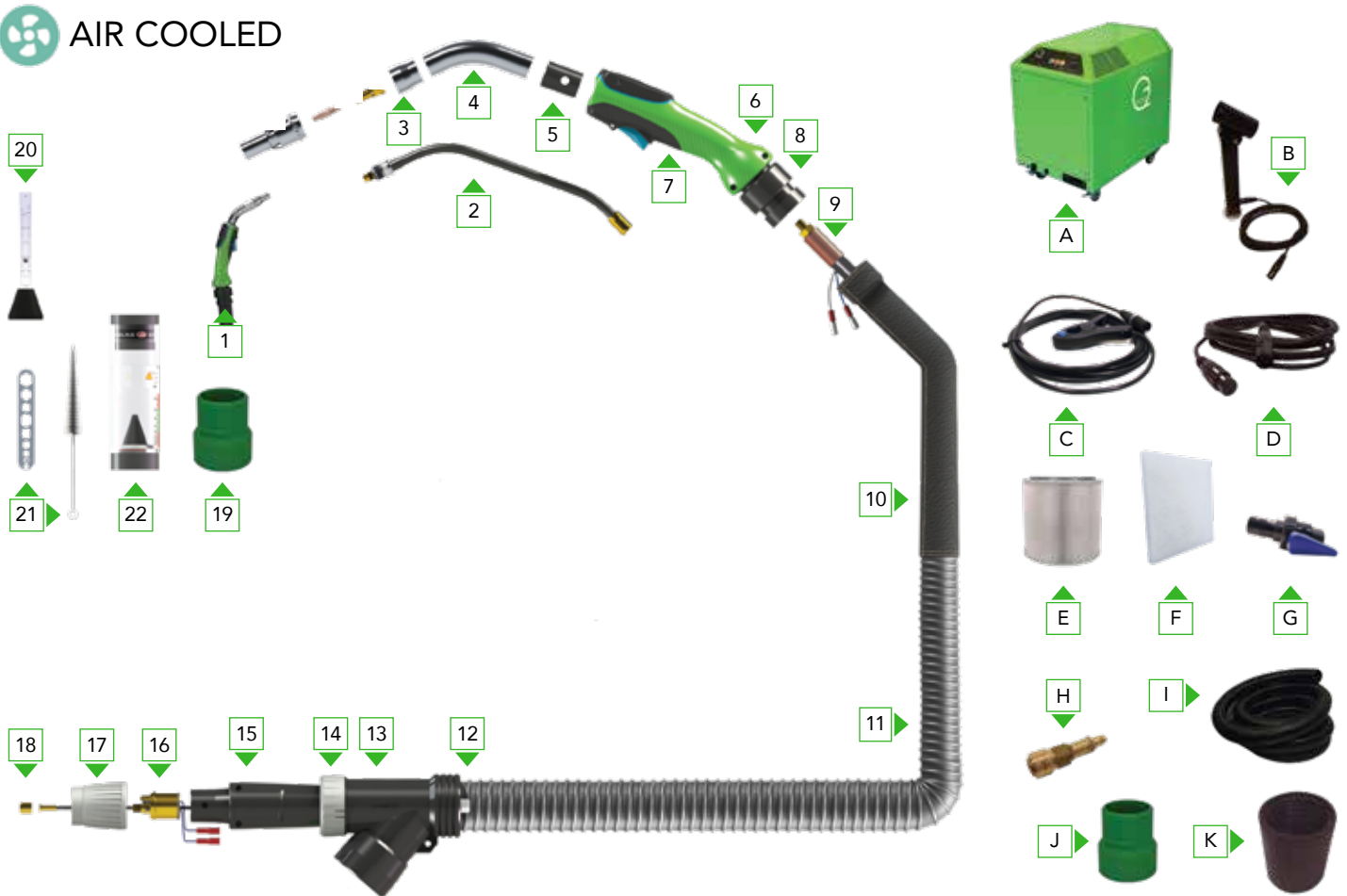

Spare Parts - GUN

Item	Part Number	Description	Item	Part Number	Description
1	TR8X01000401000	8XE MINI extractor Eur 250 amp 4 metre 45°	10	TR260019	Leather-sheathing with velcro 2mtr
	TR8X01000501000	8XE MINI extractor Eur 250 amp 5 metre 45°	11	TR340304	Fume extraction hose 30-38mm 4mtr
2	TR39301045	Swan neck 45°		TR340305	Fume extraction hose 30-38mm 5mtr
	TR3950005	PEEK ring to fix nozzle holder (not shown)	12	TR398031	Hose connection
3	TR3950000	Nozzle holder	13	TR398100	Housing (Y-shape) for fume extraction hose
4	TR3950045	Metal neck 45°	14	TR398015	Connection ring
5	TR3950500	Adapter to fit MINI neck	15	TR398010	Housing set for central connector
6	TR391000	Handle green/black complete with trigger	16	TR305298E	Central connector
7	TR391200	Trigger	17	TR8M9420	Adaptor nut
	TR391245	Spring for trigger (not shown)	18	TR305315	Liner positioner nut
	TR391250	Micro switch complete (not shown)	19	TR398110	Hose adapter
8	TR381900	Cable support set with ball-and-socket joint	20	TR406050	Gasflow metre
9	TR259264X8	Cable assembly 4mtr	21	TR371208	Tool set (brush and multitool)
	TR259265X8	Cable assembly 5mtr	22	TR371350	Airflow metre MINI Extractor

Spare Parts - EXTRACTION UNIT

Item	Part Number	Description	Item	Part Number	Description
A	TR3746150000000	W150 ClearO2 mobile fume unit 3 phase	F	TR374025	Filter Mat pk=5
	TR3746200000000	W200 ClearO2 mobile fume unit 2 welders 3 phase	G	TR374099	Ball valve to reduce the suction flow
B	TR374012	Torch holder for automatic start/stop 5 metre 250	H	TR3741061	Pressure reducing valve 5 - 15 bar 1/4-NP7.2
C	TR374010	Sensing cable auto start/stop 4 metre	I	TR37422505	ClearO2 suction hose black ø2" 5mt
D	TR3740105	Extension 5 metre for sensor cable clamp	J	TR398110	Hose adapter
E	TR374020	Main Filter	K	TR374130	Coupler to extend the suction hose

AIR COOLED

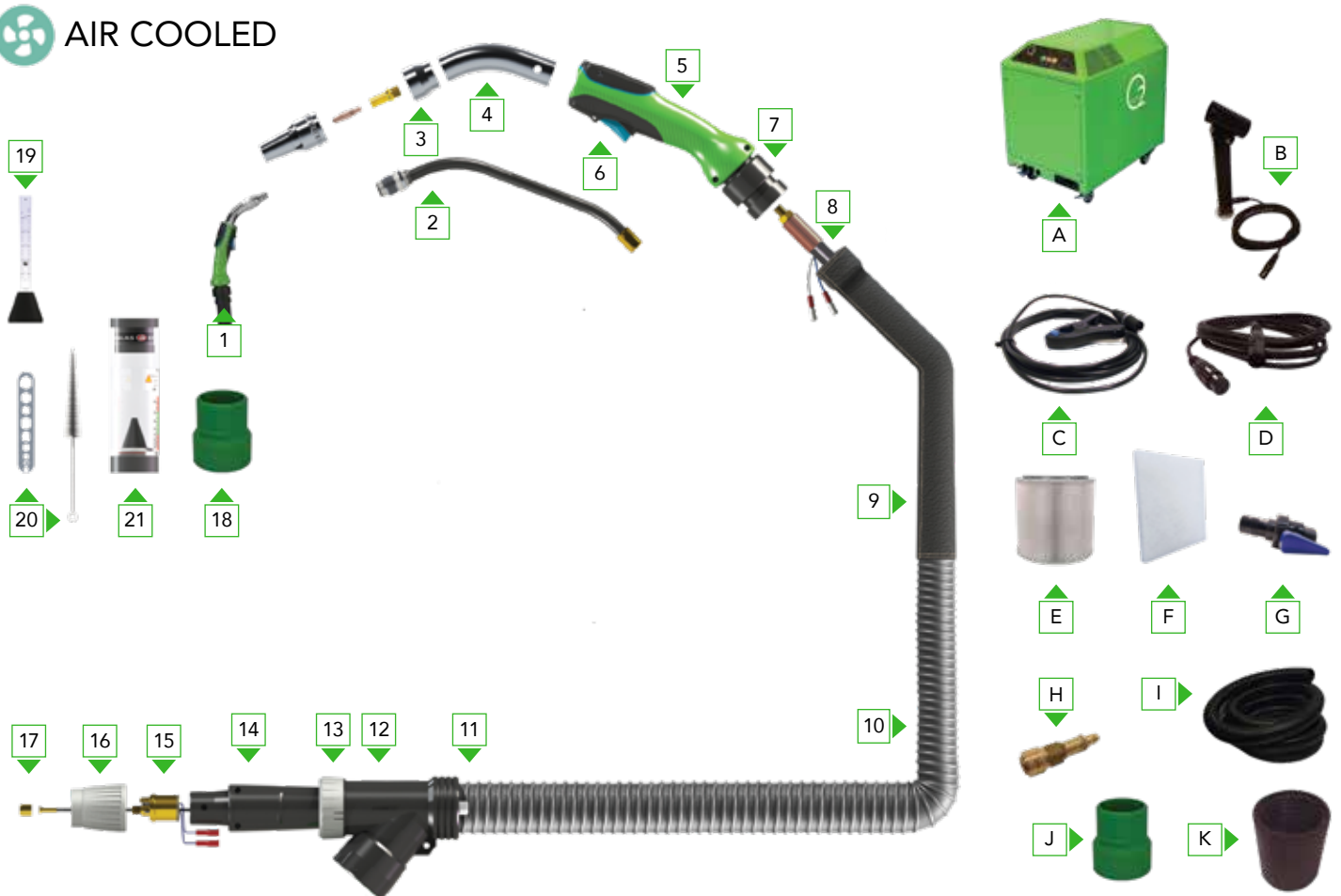

Spare Parts - GUN

Item	Part Number	Description	Item	Part Number	Description
1	TR8X04028401000	8XE extractor Eur 400 amp 4 metre 45°	10	TR3402042	Fume extraction hose 36-44mm 4mtr
	TR8X04028501000	8XE extractor Eur 400 amp 5 metre 45°		TR3402052	Fume extraction hose 36-44mm 5mtr
2	TR39302145	Swan neck 45°	11	TR398030	Hose connection
	TR3950205	PEEK ring to fix nozzle holder (not shown)	12	TR398100	Housing (Y-shape) for fume extraction hose
3	TR3950200	Nozzle holder	13	TR398015	Connection ring
4	TR3950245	Metal neck 45°	14	TR398010	Housing set for central connector
5	TR391000	Handle green/black complete with trigger	15	TR3052988	Central connector
6	TR391200	Trigger	16	TR8M9420	Adaptor nut
	TR391245	Spring for trigger (not shown)	17	TR305315	Liner positioner nut
	TR391250	Micro switch complete (not shown)	18	TR398110	Hose adapter
7	TR381920	Cable support set with ball-and-socket joint	19	TR406050	Gasflow metre
8	TR259464X8	Cable assembly 4mtr	20	TR371208	Tool set (brush and multitool)
	TR259465X8	Cable assembly 5mtr	21	TR371300	Airflow metre Extractor
9	TR260018	Leather-sheathing with velcro 2mtr			

Spare Parts - EXTRACTION UNIT

Item	Part Number	Description	Item	Part Number	Description
A	TR3746150000000	W150 ClearO2 mobile fume unit 3 phase	F	TR374025	Filter Mat pk=5
	TR3746200000000	W200 ClearO2 mobile fume unit 2 welders 3 phase	G	TR374099	Ball valve to reduce the suction flow
B	TR374014	Torch holder for automatic start/stop 5 metre 400	H	TR3741061	Pressure reducing valve 5 - 15 bar 1/4-NP7.2
C	TR374010	Sensing cable auto start/stop 4 metre	I	TR37422505	ClearO2 suction hose black ø2" 5mtr
D	TR3740105	Extension 5 metre for sensor cable clamp	J	TR398110	Hose adapter
E	TR374020	Main Filter	K	TR374130	Coupler to extend the suction hose

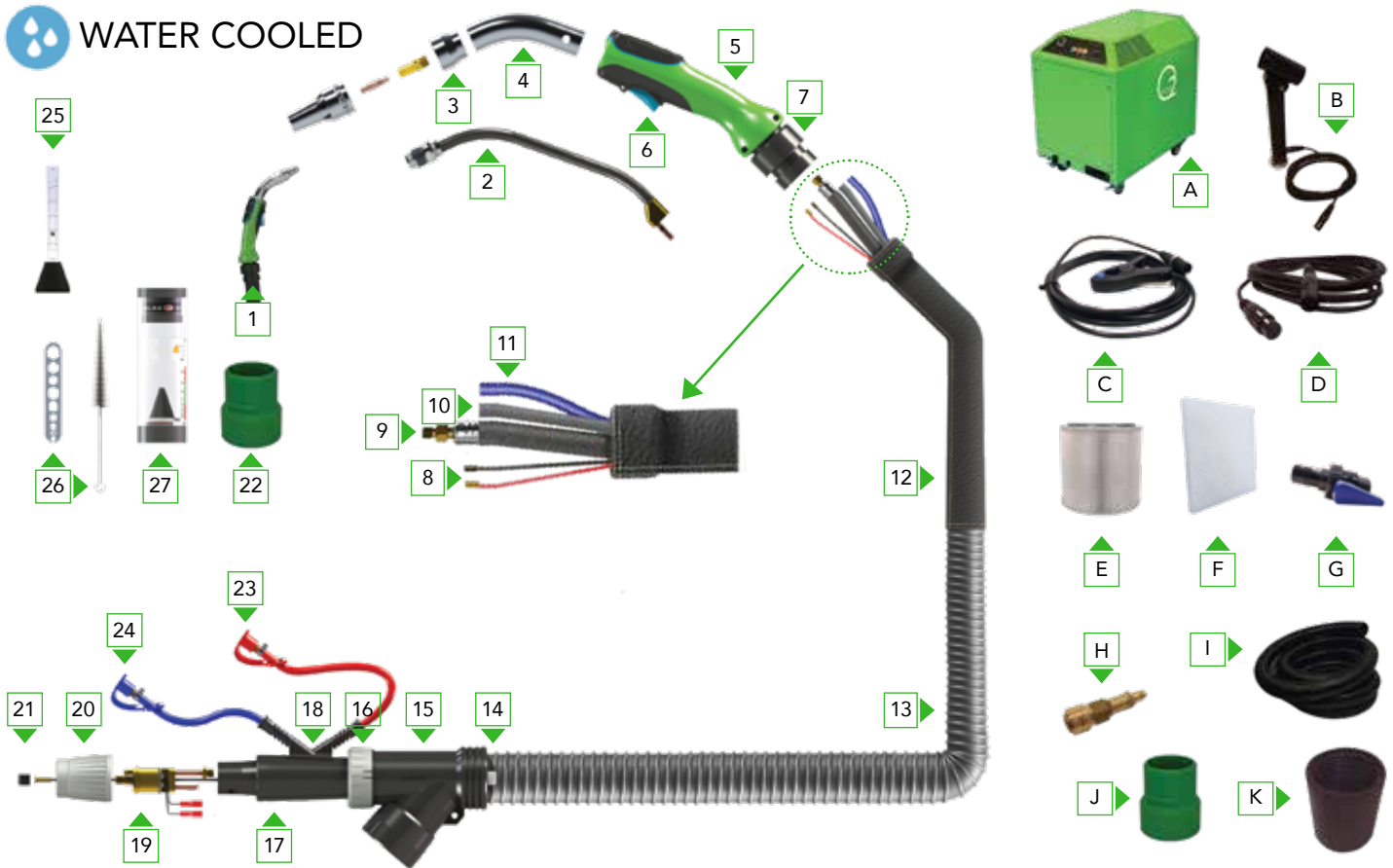

Spare Parts - GUN					
Item	Part Number	Description	Item	Part Number	Description
1	TR8X05060401000	8XE extractor Eur 500 amp 4 metre 45°	12	TR260018	Leather-sheathing with velcro 2mtr
	TR8X05060501000	8XE extractor Eur 500 amp 5 metre 45°	13	TR3402042	Fume extraction hose 36-44mm 4mtr
2	TR39303045	Swan neck 45°		TR3402052	Fume extraction hose 36-44mm 5mtr
	TR3950205	PEEK ring to fix nozzle holder (not shown)	14	TR398030	Hose connection
3	TR3950200	Nozzle holder	15	TR398100	Housing (Y-shape) for fume extraction hose
4	TR3950245	Metal neck 45°	16	TR398015	Connection ring
5	TR391000	Handle green/black complete with trigger	17	TR398010	Housing set for central connector
6	TR391200	Trigger	18	TR350881	Water hose guide
	TR391245	Spring for trigger (not shown)	19	TR305304E2	Central connector
	TR391250	Micro switch complete (not shown)	20	TR8M9420	Adapter nut
7	TR381920	Cable support set with ball-and-socket joint	21	TR305315	Liner positioner nut
8	TR306505	Switch cable 1x0.75mm ² per mtr	22	TR398110	Hose adapter
9	TR258514X8	Power/water cable 4mtr	23	TR258701	Waterstop red
	TR258515X8	Power/water cable 5mtr	24	TR258702	Waterstop blue
10	TR2585314XE	Outer liner 4mtr	25	TR406050	Gasflow metre
	TR2585315XE	Outer liner 5mtr	26	TR371208	Tool set (brush and multitool)
11	TR258535	Water inlet hose 5x8mm blue per mtr	27	TR371300	Airflow metre extractor
	TR258566	Water outlet hose 5x8mm red per mtr			

Spare Parts - EXTRACTION UNIT					
Item	Part Number	Description	Item	Part Number	Description
A	TR3746150000000	W150 ClearO2 mobile fume unit 3 phase	F	TR374025	Filter Mat pk=5
	TR3746200000000	W200 ClearO2 mobile fume unit 2 welders 3 phase	G	TR374099	Ball valve to reduce the suction flow
B	TR374014	Torch holder for automatic start/stop 5 metre 500	H	TR3741061	Pressure reducing valve 5 - 15 bar 1/4-NP7.2
C	TR374010	Sensing cable auto start/stop 4 metre	I	TR37422505	ClearO2 suction hose black ø2" 5mt
D	TR3740105	Extension 5 metre for sensor cable clamp	J	TR398110	Hose adapter
E	TR374020	Main Filter	K	TR374130	Coupler to extend the suction hose

AIR QUALITY IN YOUR WORKSHOP

When you consider a welding fume particle that is 0.5 µm in size can take 2 days to reach the floor when released from a height of 1.5 metres, you begin to understand how long these carcinogenic particles can remain suspended in the air. This is vital to consider when sharing a work environment with welders, as the air could contain respiratory hazards long after welding has been completed.

On-gun fume extraction can assist in reducing exposure to welding fume and other airborne contaminants, not only for the welder, but also for those who work near welding operations. This is the key difference between on-gun fume extraction and Personal Protective Equipment (PPE) used by the welder. PPE can only protect the welder, while on-gun fume extraction can protect the welder and stop the spread of fume throughout the workplace protecting all workers from welding fume exposure.

For this reason, on-gun fume extraction can be the most economical method to protect all workers from welding fume exposure in shared working environments.



UP TO 98% CAPTURE RATE & 100% DUTY CYCLE

**REMOVES FUME AND FOLLOWS THE WELDER
UNLIKE OTHER FORMS OF LEV**





AWS was established in 1994 and has played a key role in the welding industry ever since.

As a company that specialises in welding fume safety equipment, it is our goal to raise awareness on the important issues that welders face.

AWS is the sole agent and exclusive wholesaler for the 3M™ Speedglas™ Welding Safety Brand, 3M™ Adflo™ Powered Air Purifying Respirators, the range of Nederman Portable LEV FPS Fume Extractors, and the Translas On-Gun Fume Extraction Range in Australia and New Zealand (ANZ).

For more information on welding PPE, welding fume monitoring, or welding fume extraction options, please contact AWS.

www.apexweldingsafety.com.au

Apex Welding Safety Pty Ltd
T: (02) 9439 0111
E: sales@apexweldingsafety.com.au

© Apex Welding Safety Pty Ltd 2022 All rights reserved

References
1. 2019 Honaryar MK, Lunn RM, Luce D, et al. Occup Environ Med



► BY WELDERS. FOR WELDERS

Based in the Netherlands, Translas was founded by welders, for welders, with a passion for innovation and new technologies and have been manufacturing welding guns since 1960.

Translas continually strives to engineer industry leading and innovative products that boast distinctive design, quality, and functionality.